

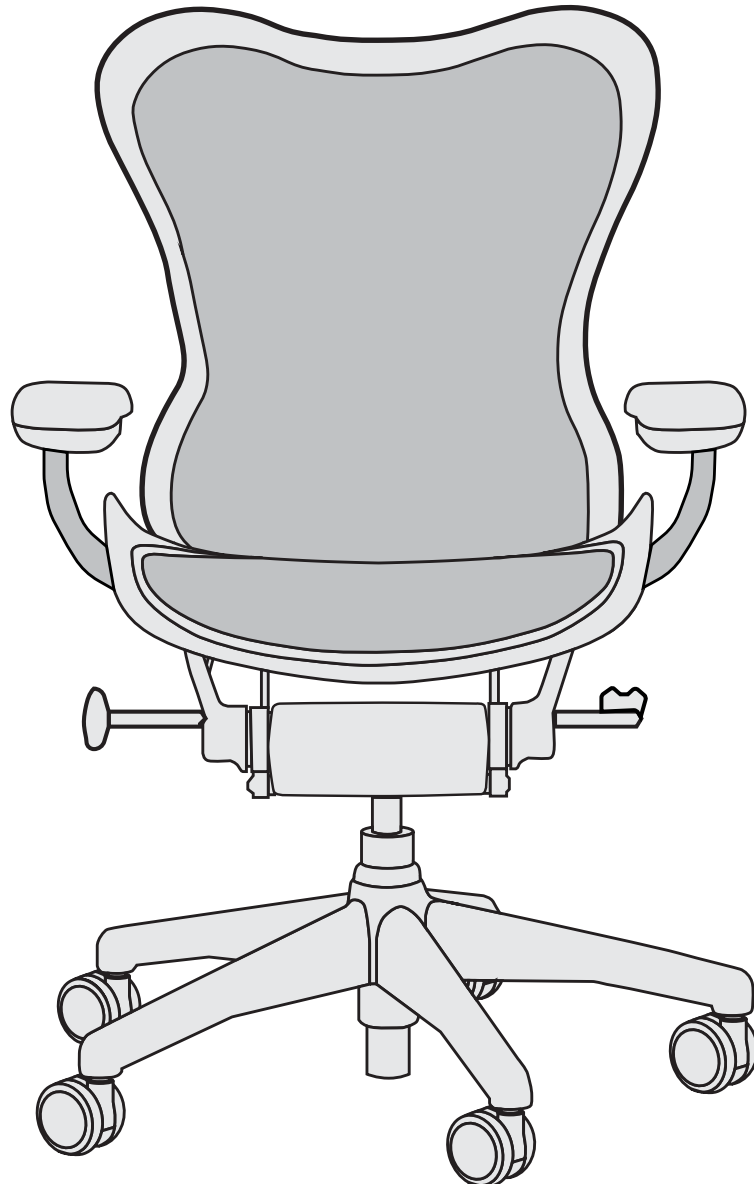

**SYSTEMS**  
Office Furniture

# Refurbished Herman Miller Mirra v1

Partial Assembly



**Assembly  
Code: 16-1**

Have a question or need help with assembly? Reach out to us.

Monday - Friday  
8:00 am - 5:00 pm CST  
**979.776.2100**  
SystemsOffice.com

If you are missing parts or discover defects and/or damage while assembling this product, you could be eligible for a replacement free of charge. We are always here to help.

**Visit Our Assembly Page**



[SystemsOffice.com/assembly](https://SystemsOffice.com/assembly)

# What's in the box?

Chair Body

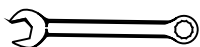
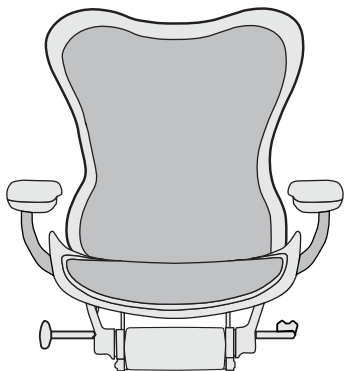

Wrench

Base

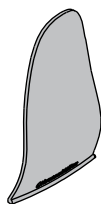
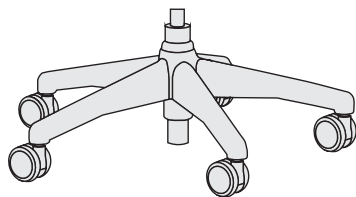

Access Cover



M10 Bolts (2)

## Step One

Place the **Chair Body** onto the **Cylinder**. Sit on the seat to lock it into place.

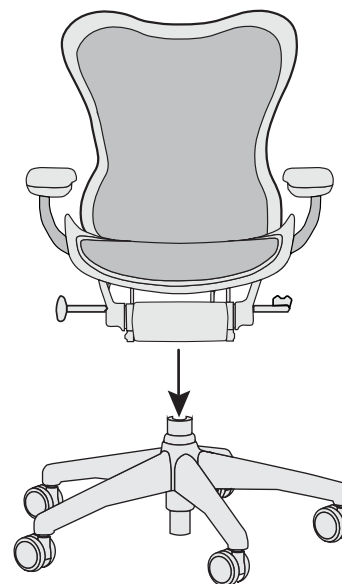

## Step Two

Get up and turn the chair around. On the **Chair Body**, locate two holes in the lumbar area. Install the two provided **M10 bolts** by hand until finger tight. Using the provided wrench, tighten the bolts, careful not to overtighten.

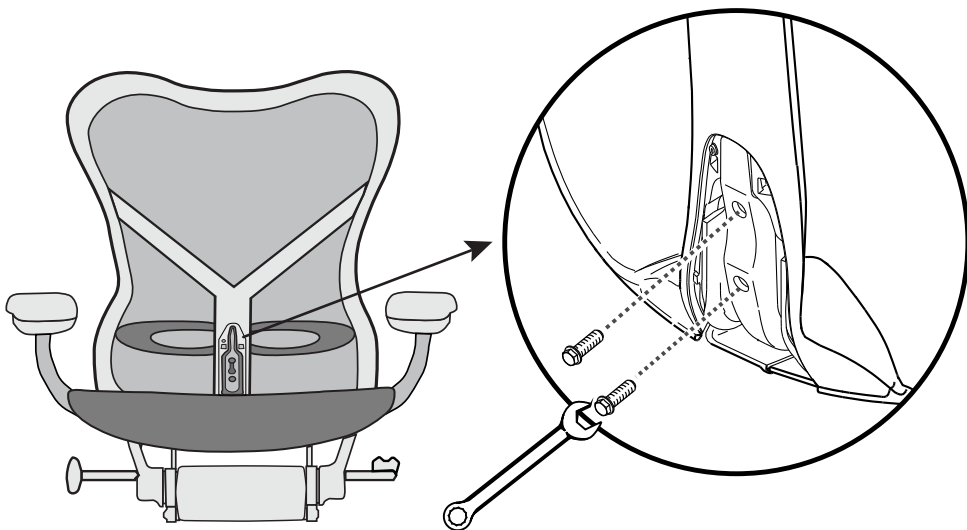

## Step Three

Place the **Access Cover** lower lip onto the rear edge of the chair back. Rotate the **Access Cover** and snap the top into place by hand until the surfaces are flush. That's all there is to it. Now you can enjoy your chair.

