



SYSTEMS
Office Furniture

Refurbished Steelcase Move

Multi-Part Assembly

**Assembly
Code: 11-1**

Have a question or need help with assembly? Reach out to us.

Monday - Friday
8:00 am - 5:00 pm CST
979.776.2100
SystemsOffice.com

If you are missing parts or discover defects and/or damage while assembling this product, you could be eligible for a replacement free of charge. We are always here to help.

Visit Our Assembly Page



SystemsOffice.com/assembly

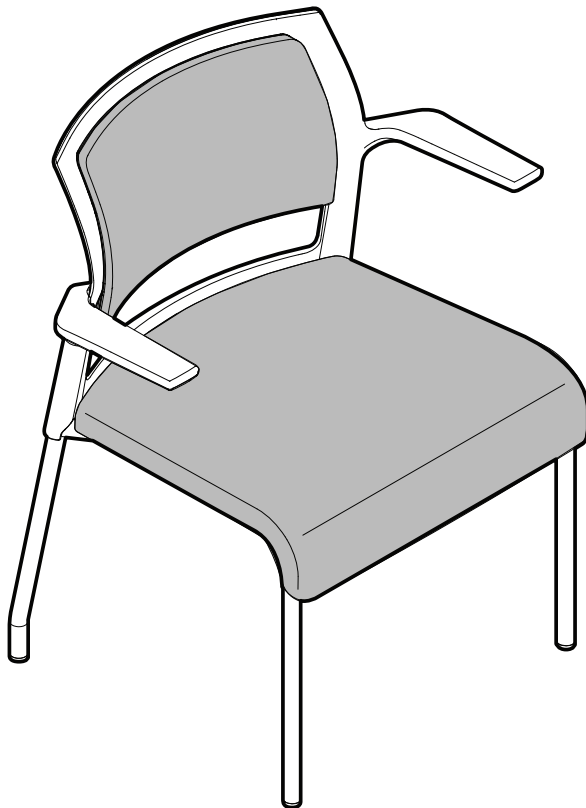

Without Casters

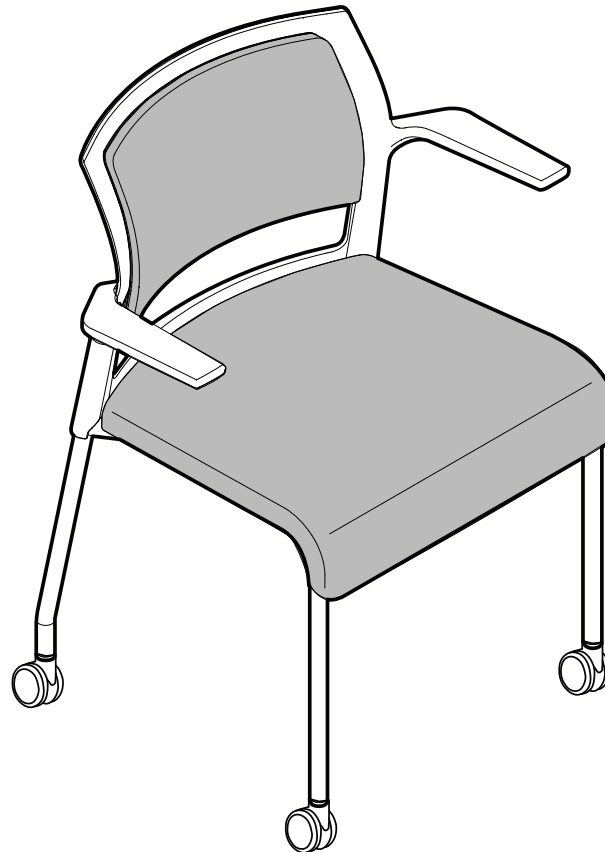

With Casters

What's in the box?

Seat Back & Arms

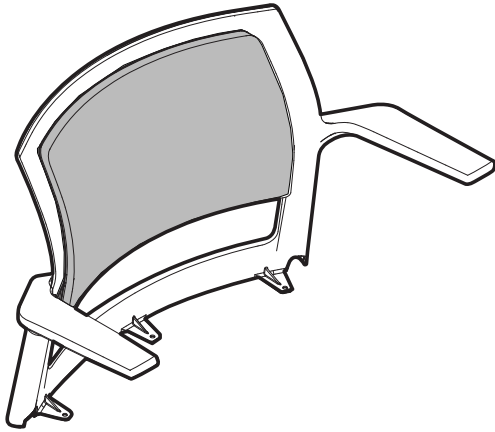

Seat Pan

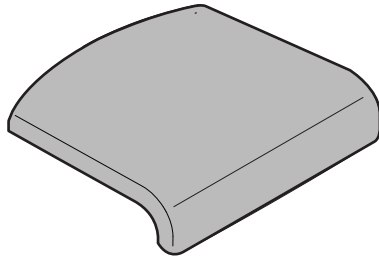

Chair Frame

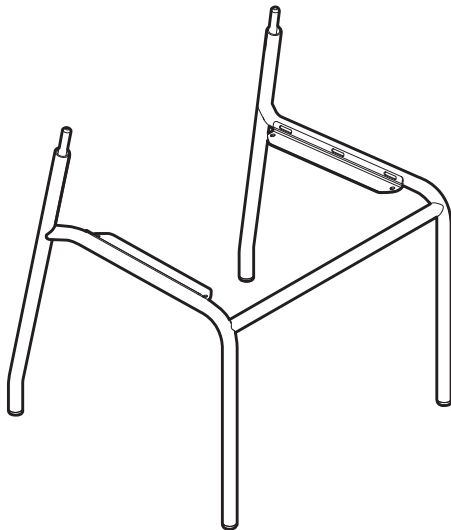

Allen Key

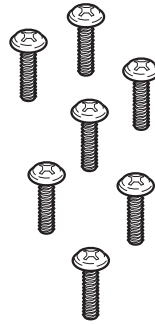

Screws (7)

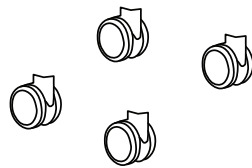

Optional Casters (4)

Step One

Place the **Seat Back & Arms** into the **Chair Frame**.

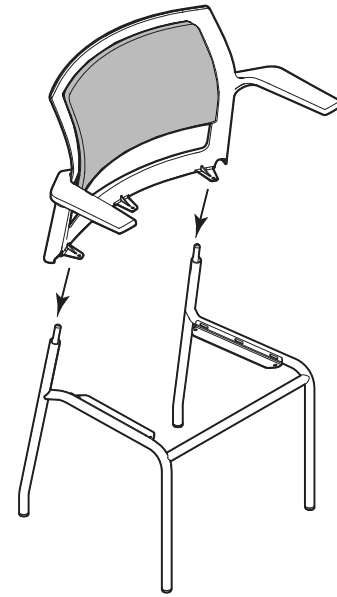

Step Two

Press the **Seat Pan** down into the **Chair Frame**.

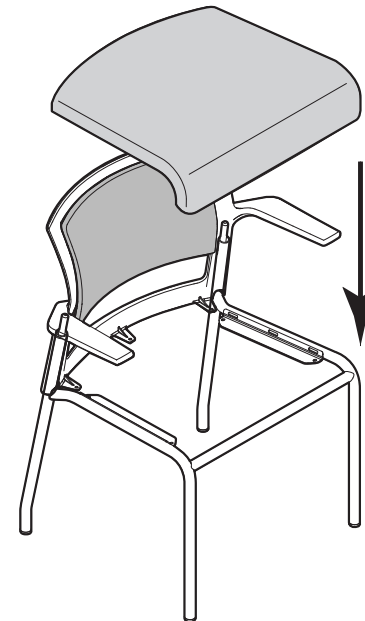

Step Three

Flip over the partially assembled chair so you can get a clear view underneath the chair.

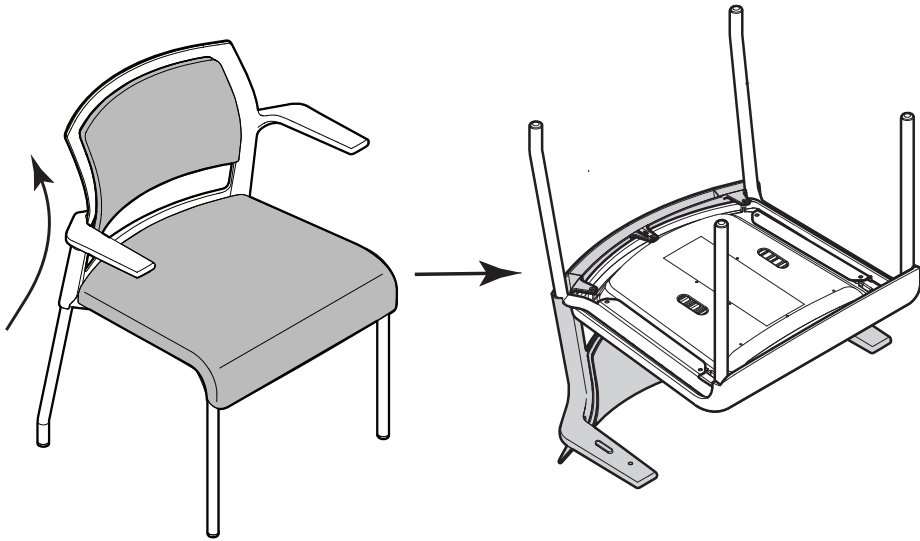

Step Four

Insert three screws into the holes that line up the **Chair Back & Arms** with the **Chair Frame** and **Seat Pan**. Tighten with provided **Allen Key**.

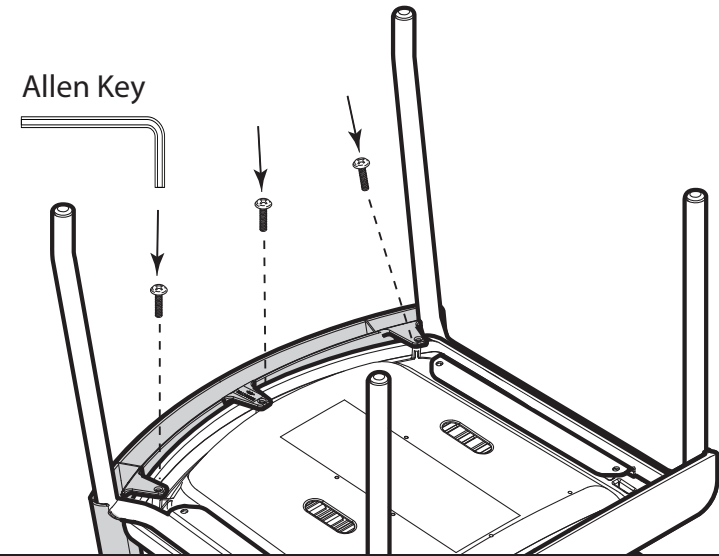

Step Five

Insert four screws into the holes on each corner of the **Seat Pan** to secure it to the **Chair Frame**. Tighten with the provided **Allen Key**.

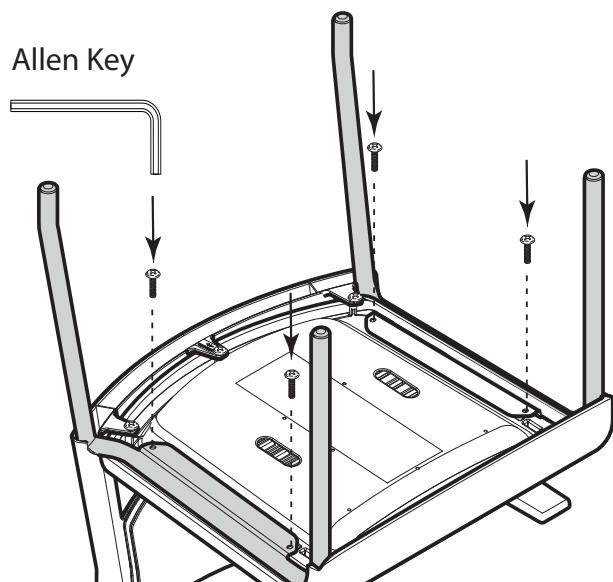

Step Six

Optional: If there are **Casters** included, snap each of wheel into the bottom of each leg of the **Chair Frame**. Enjoy your chair!

