



Scan Me
to watch
Assembly
Instructions



Kai
— By —
i5 Industries

Assembly: Conference Table

MODELS: CT71 71" Conference Table

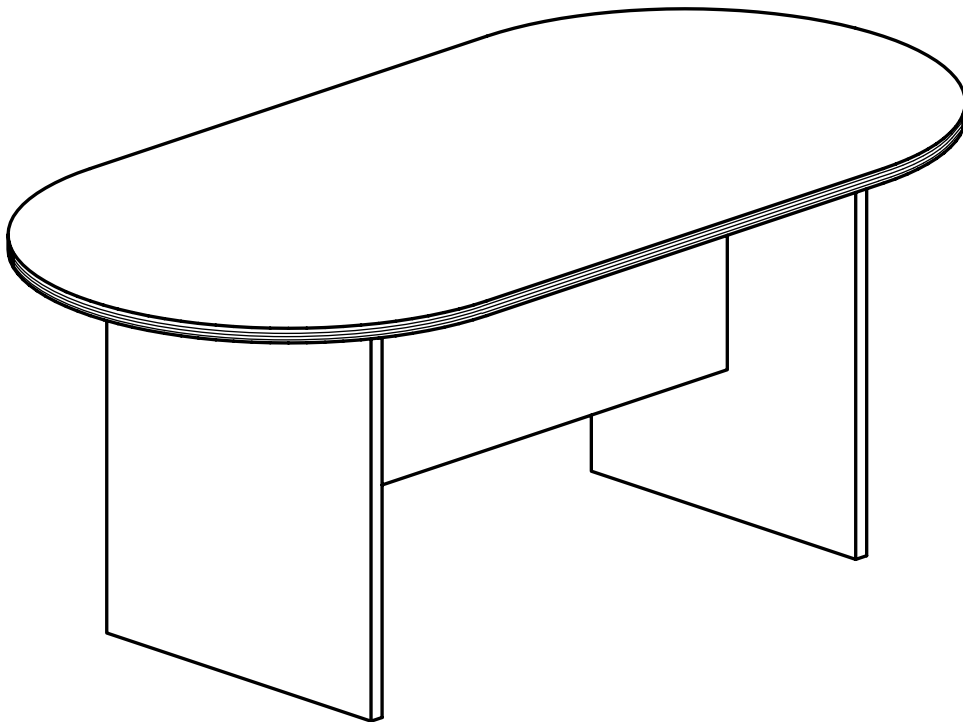

- Place all laminated parts on a clean and smooth surface such as a rug or carpet to avoid the parts from being scratched.
- Check to be sure that you have all parts and hardware.
- Remove all wrapping materials, including staples & packing straps before you start to assemble.
- Line up holes for cam locks.
- Put on sticker caps last.
- Keep all hardware parts out of reach of children.
- Inspect all holes to ensure there isn't any debris.



**TWO PEOPLE ARE
REQUIRED TO
ASSEMBLE AND MOVE
THIS MODEL**

Required tools:



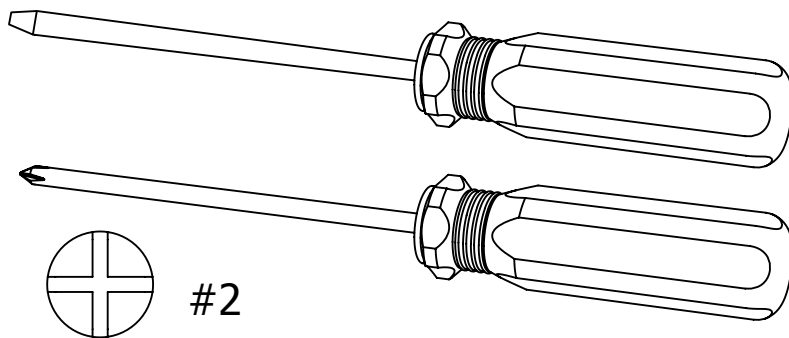

Flathead or Philips
#2 Screwdriver

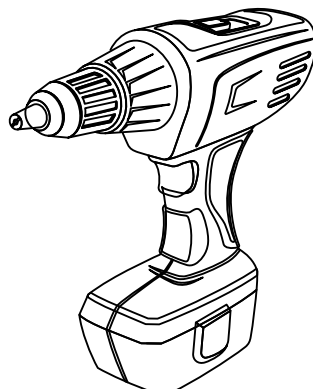

Recommended tools:

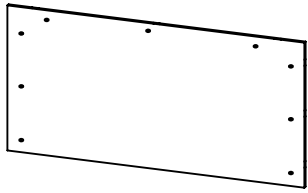
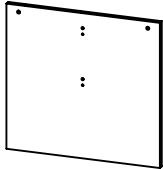
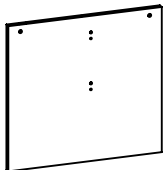
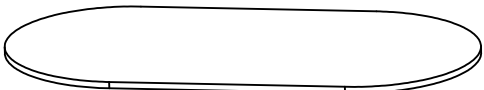
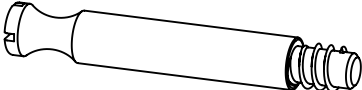
**Highly recommended when
assembling: L-shape
configuration or
attaching pedestals**

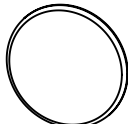

PART	QTY.	
MODESTY PANEL	1	
RIGHT SIDE END PANEL	1	
LEFT SIDE END PANEL	1	
TOP	1	
PART	QTY.	
A Metal Pin	11	
B Cam Lock	11	
C Set Screw	11	
D Cap Sticker	11	
E Adjustable Glide	4	
F Wood Dowel	11	

Assemble modesty panel with end panels.

2X (F)
Insert by
hand only

2X (A)

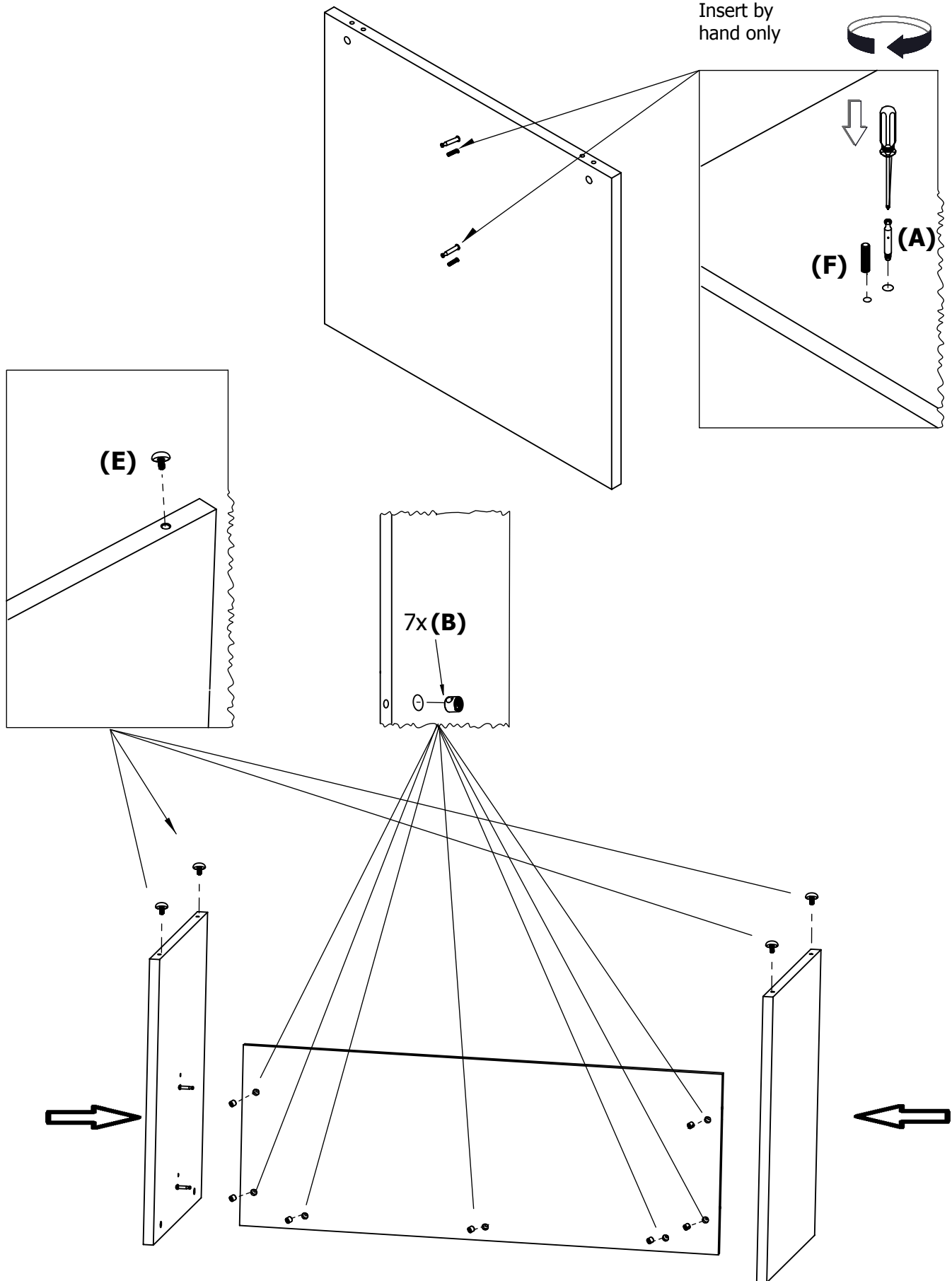

Place all hardware in correct holes. Once that is complete line the holes up and place the base onto the top. Use set screw (C) to lock all cams and metal pins in place.

7X (F)

7X (A)

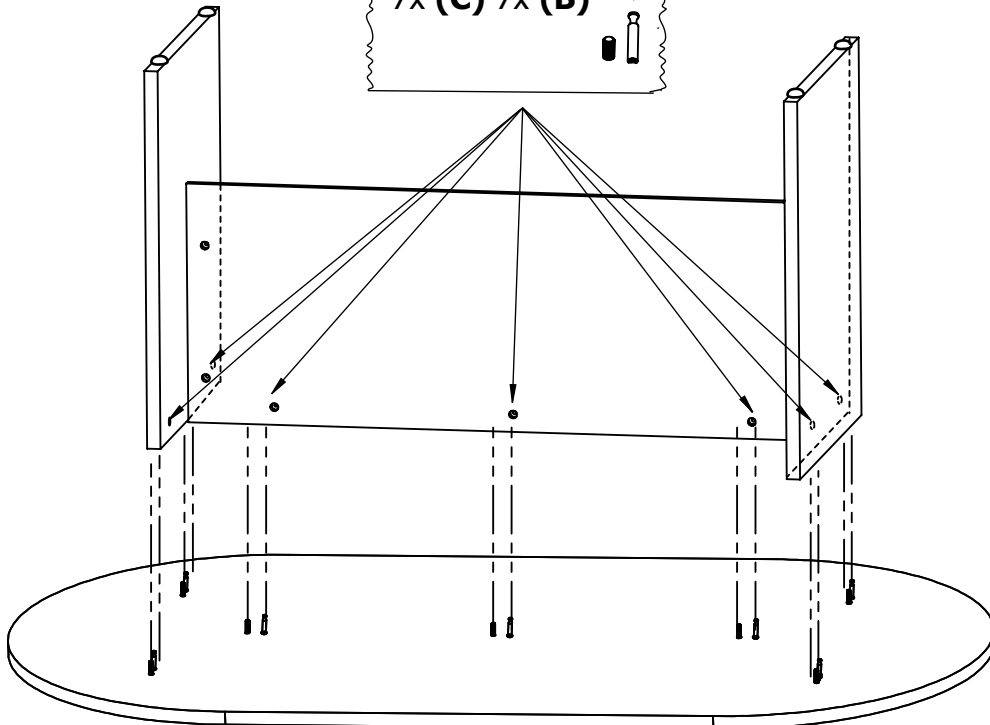
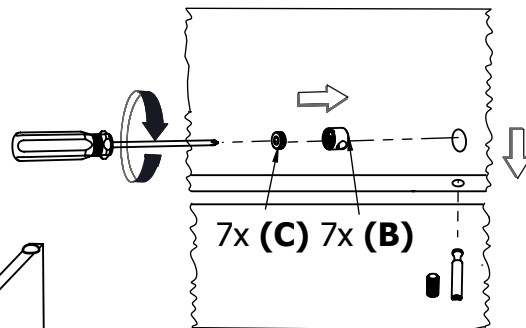
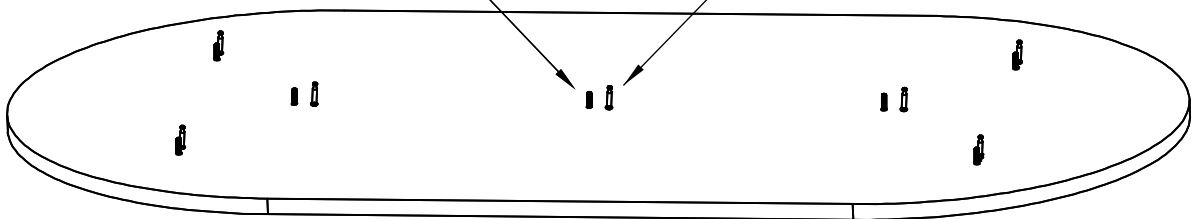
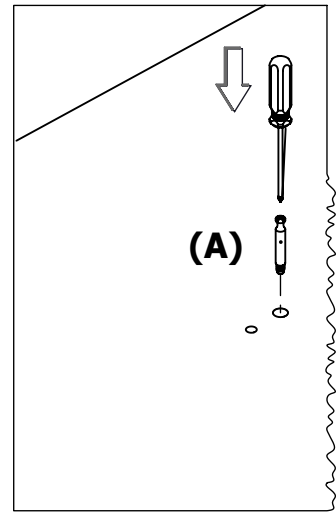
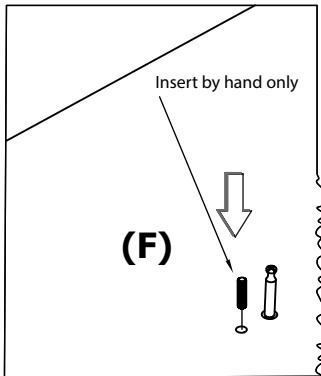

Note: Place cap stickers on any exposed holes.



**TWO PEOPLE ARE
REQUIRED TO
FLIP AND MOVE
THIS MODEL**

